



CPCI-USB-5

CPCI-USB 2.0 Interface with 6 USB Ports



Hardware Manual

to Product I.2326.xx



NOTE

The information in this document has been carefully checked and is believed to be entirely reliable. esd makes no warranty of any kind with regard to the material in this document, and assumes no responsibility for any errors that may appear in this document. esd reserves the right to make changes without notice to this, or any of its products, to improve reliability, performance or design.

esd assumes no responsibility for the use of any circuitry other than circuitry which is part of a product of esd gmbh.

esd does not convey to the purchaser of the product described herein any license under the patent rights of esd gmbh nor the rights of others.

esd electronic system design gmbh
Vahrenwalder Str. 207
30165 Hannover
Germany

Phone: +49-511-372 98-0
Fax: +49-511-372 98-68
E-Mail: info@esd.eu
Internet: www.esd.eu

USA / Canada:
esd electronics Inc.
525 Bernardston Road
Suite 1
Greenfield, MA 01301
USA

Phone: +1-800-732-8006
Fax: +1-800-732-8093
E-mail: us-sales@esd-electronics.com
Internet: www.esd-electronics.us

Trademark Notices

USB is a registered trademark of the Universal Serial Bus Implementers Forum, INC.

All other trademarks, product names, company names or company logos used in this manual are reserved by their respective owners.

Document file:	I:\Texte\Doku\MANUALS\CPCI\CPCI-USB-5\English\CPCI-USB-5_Hardware_en_1.0.odt
Date of print:	2010-06-02

Firmware version:	from Rev. 1.0
--------------------------	---------------

Document History

The changes in the document listed below affect changes in the hardware as well as changes in the description of the facts, only.

Revision	Chapter	Changes versus previous version	Date
1.0	-	First English version	2010-06-02

Technical details are subject to change without further notice.



Safety Instructions

- When working with CPCI-USB-5 follow the instructions below and read the manual carefully to protect yourself and the CPCI-USB-5 from damage.
The esd guarantee does not cover damages which result from improper use or disregard of safety instructions and warnings.
- The CPCI-USB-5 does not require any manual configuration of the hardware.
- In order to prevent overvoltage damage due to thunder storm, unplug the device from USB and CAN beforehand.
- Protect the CPCI-USB-5 from dust, moisture and steam.
- Protect the CPCI-USB-5 from shocks and vibrations.
- The CPCI-USB-5 may become warm during normal use. Always allow adequate ventilation around the CPCI-USB-5 and use care when handling.
- Do not operate the CPCI-USB-5 adjacent to heat sources and do not expose it to unnecessary thermal radiation. Ensure an ambient temperature as specified in the technical data.
- Do not use damaged or defective cables to connect the CPCI-USB-5 and follow the CAN wiring hints at the end of the manual.
- The CPCI-USB-5 is intended for installation in a CompactPCI system only.
- The operation of the CPCI-USB-5 in hazardous areas, or areas exposed to potentially explosive materials is not permitted.
- The operation of the CPCI-USB-5 for medical purposes is prohibited.

Table of contents

1. Overview.....	7
1.1 Module Description.....	7
2. PCB View with Position of the Connectors.....	8
3. Hardware Installation.....	9
4. LEDs.....	11
4.1 Front Panel with Connector and LED Description.....	11
4.1.1 LEDs USB1-USB5.....	11
4.1.2 LEDs 1-8.....	12
4.1.2.1 User-Specific LEDs (LED1-7).....	12
5. Monitoring of the Local Power Supply Voltage.....	13
6. Summary of Technical Data.....	14
6.1 General Technical Data.....	14
6.2 USB-Interface	14
6.3 CompactPCI Bus.....	15
6.4 CompactFlash Interface.....	15
6.5 Secure Digital Interface.....	15
6.6 System Health Controller.....	15
6.7 Software Support.....	15
6.8 Order Information.....	16
7. Connector Assignment.....	17
7.1 External USB (USB 1 - USB 5).....	17
7.2 Internal USB	18

This page is intentionally left blank.

1. Overview

1.1 Module Description

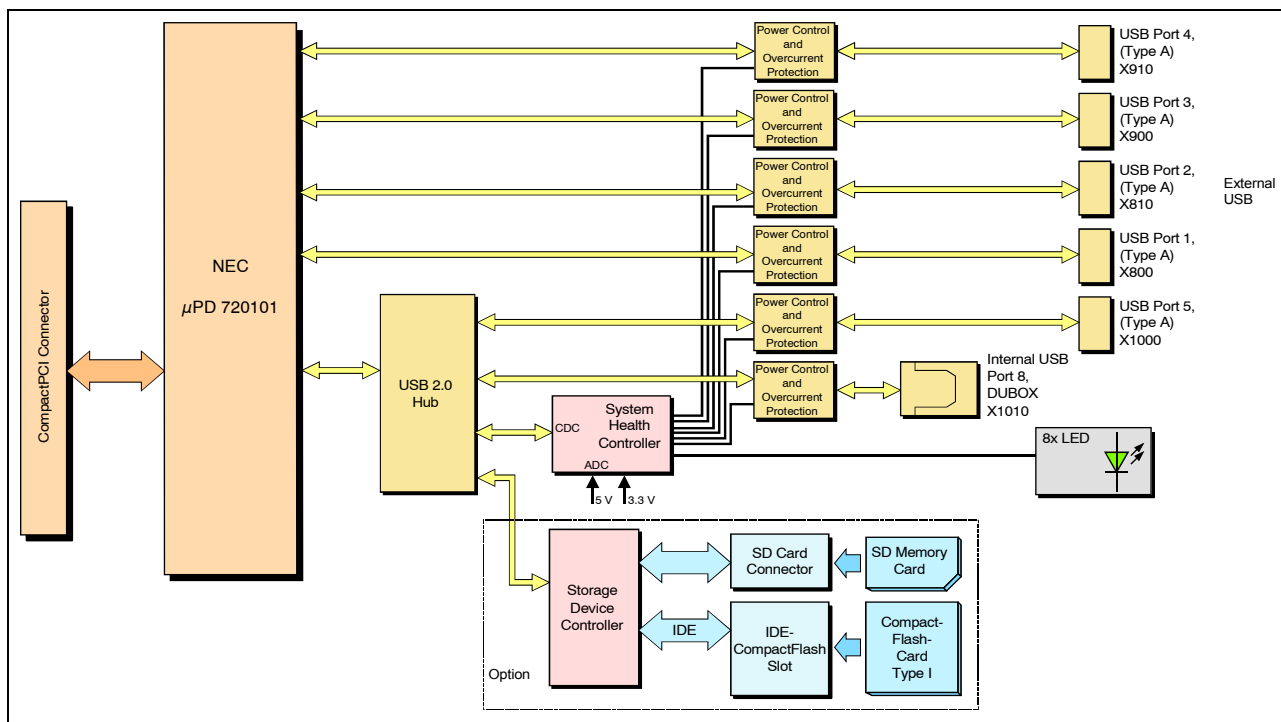

Figure 1: Block-circuit diagram of the CPCI-USB-5

The CPCI-USB-5 is a CompactPCI board in 3U format. It is equipped with a NEC μ PD720101, a USB 2.0 host controller that supports 5 Hi-Speed USB 2.0 interfaces. One of them is multiplied by an on-board HUB.

The 5 external USB 2.0 interfaces are accessible via USB connectors (type A, female) in the front panel. The internal USB 2.0 interface is accessible via a 5-pin DUBOX connector located on the board. Power control and overcurrent protection are ensured for all 6 USB interfaces.

The CDC-device reduces the starting current by sequentially powering up the USB ports.

Optionally, the CPCI-USB-5-CF/SD is additionally available with an on-board CompactFlash card slot and a SD memory card slot.

The CPCI-USB-5 runs with standard USB-Serial system-drivers of the common operating systems.

2. PCB View with Position of the Connectors

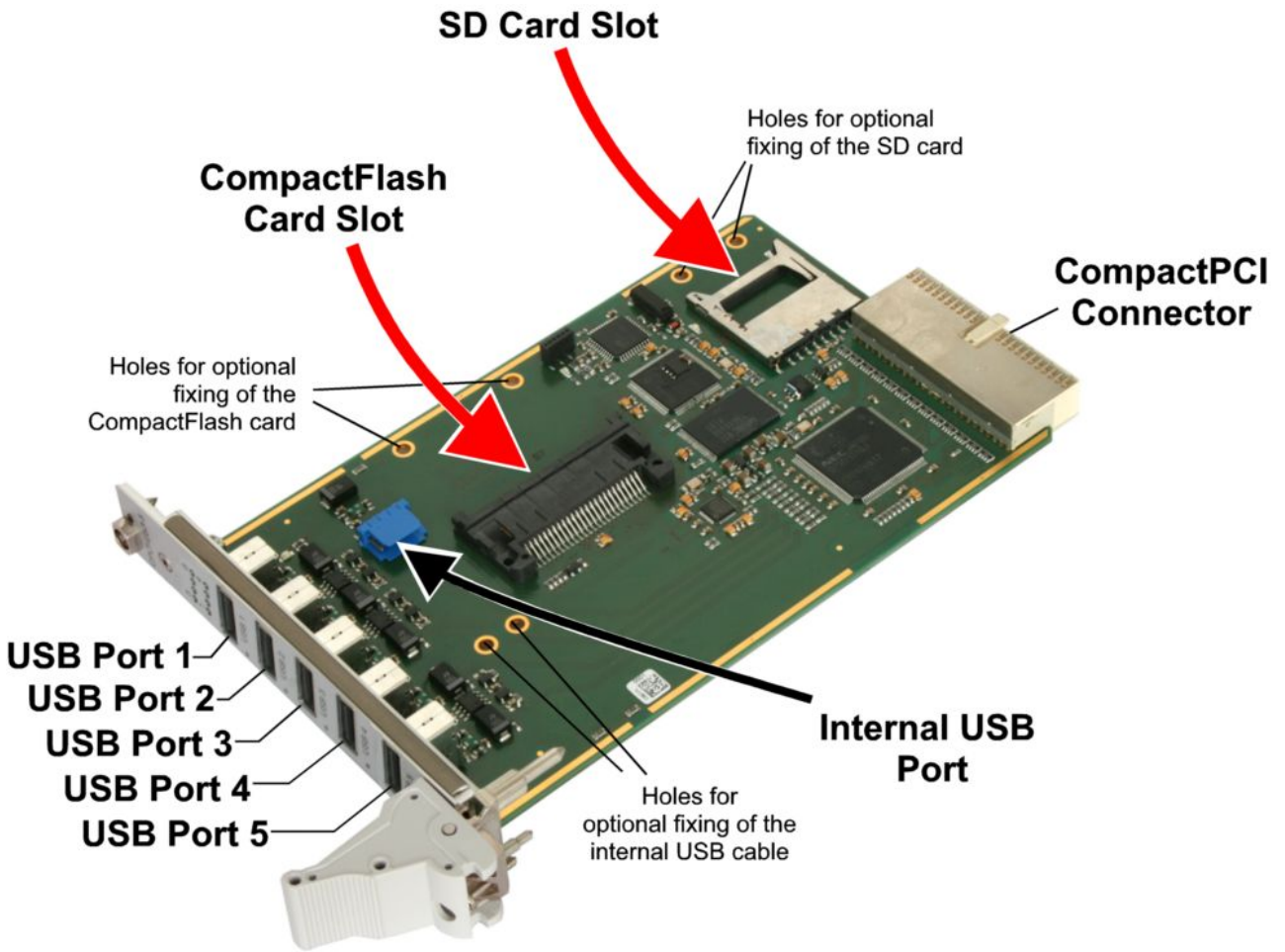

Figure 2: Connecting diagram of CPCI-USB-5

3. Hardware Installation



Read the safety instructions at the beginning of this document carefully, before you start with the hardware installation!



Danger!

Electric shock risk. Never carry out work while power supply voltage is switched on!



Attention !

Electrostatic discharges may cause damage to electronic components. To avoid this, please perform the following steps *before* you touch the CPCI-USB-5, in order to discharge the static electricity from your body:

- Switch off the power of your computer, but leave it connected to the mains until you have discharged yourself (if applicable).
- Please touch the metal case of the computer now to discharge yourself.
- Furthermore, you should prevent your clothes from touching the computer, because your clothes might be electrostatically charged as well.

Procedure:

1. Switch off your computer and all connected peripheral devices (monitor, printer, etc.).
2. Discharge your body as described above.
3. Disconnect the computer from the mains.
If the computer does not have a flexible mains cable, but is directly connected to mains, disconnect the power supply via the safety fuse and make sure that the fuse cannot switch on again unintentionally (i.e. with caution label).



Danger!

Never carry out work while power supply voltage is switched on!

4. CPCI-USB-5-CF/SD card only:
If applicable insert your CompactFlash card and/or your SD memory card into the corresponding slots (see figure 2).
The board comes with 3.2 mm holes for optional fixing of the memory cards.
5. Connect the internal USB line (USB port 8) via the 5-pin DUBOX connector (X1010) to the internal USB port (see figure 2).
The board comes with two 3.2 mm holes for optional fixing the internal USB-cable for strain relief, e.g. by means of cable ties.
6. Insert the CPCI-USB-5 into a free CompactPCI Slot in your PC.
7. Fix the CPCI-USB-5 with the screws on the front panel.
8. Connect the external USB lines (USB1-USB5) to the USB connectors in the front panel (see Figure 2). The external USB lines are 'hot-pluggable' and can be connected or disconnected later.

Hardware Installation

9. Connect the computer to mains again (mains connector or safety fuse).
10. Switch on the computer and the peripheral devices.
11. End of hardware installation.
12. Set the interface properties in your operating system. For further information refer to the documentation of the operating system.

4. LEDs

4.1 Front Panel with Connector and LED Description

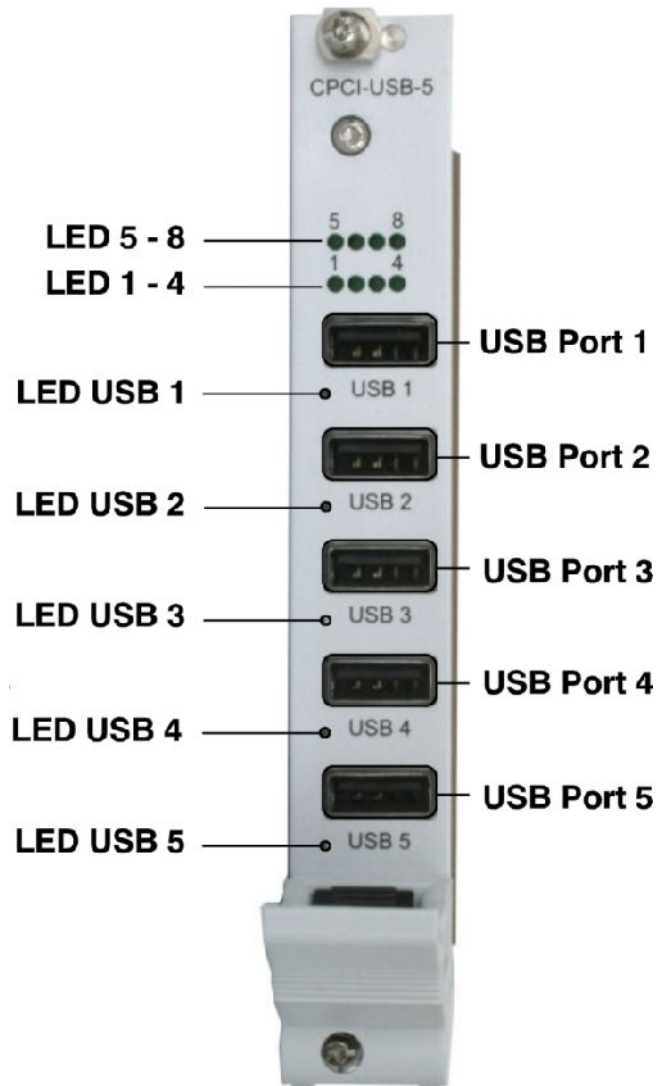

Figure 3: Front panel CPCI-USB-5

4.1.1 LEDs USB1-USB5

Name/ Labelling	Description	LED- Description in Schematics Diagram
USB 1	When powering up the system the LEDs are sequentially turned on corresponding to sequentially powering up the USB ports.	LED1000
USB 2		LED800
USB 3		LED810
USB 4	After powering up the system these LEDs are permanently on.	LED900
USB 5		LED910

4.1.2 LEDs 1-8

Name/ Labelling	Colour	Description	LED- Description in Schematics Diagram
1	green	user-specific (see following chapter)	LED660A
2	green		LED660B
3	green		LED660C
4	green		LED660D
5	green		LED661A
6	green		LED661B
7	green		LED661C
8	green	internal storage medium LED is on if there is access to the CompactFlash- and/or SD-memory card	LED661D

4.1.2.1 User-Specific LEDs (LED1-7)

The LEDs 1-7 can be addressed via standard USB-serial-system drivers of the common operating systems as a virtual serial interface.

A string, containing the command and the desired LED-status as parameter, has to be send to the corresponding serial interface.

The call contains the command *LED* and the binary value of the LED-status as 2 hexadecimal nibble.

Call: "LED *parameter*"

Parameter-Description:

Assignment of the LEDs to the parameter bits:								
Bit	7	6	5	4	3	2	1	0
LED	not evaluated	7	6	5	4	3	2	1

LED-Status:	LED-Status	Binary value
	LED on	1
	LED off	0

Example:

Call	Meaning
LED01	LED 1 is on
LED03	LED 1 and LED 2 are on
LED05	LED 1 and LED 3 are on
LED07	LED 1, LED 2 and LED 3 are on
:	:
LED7F	all LEDs (1-7) are on

5. Monitoring of the Local Power Supply Voltage

The local power supply voltage is monitored by the system health controller.

The ADC values measured can be read via standard USB-serial system drivers of the common operating systems. The system health controller is addressed as a virtual serial interface.

To request the current values of the 5 V- and 3.3 V-power supply voltage the command *ADC* has to be send to the corresponding serial interface.

Call: 'ADC'

Output: By the health controller currently measured actual values of the local 5 V- and 3.3 V-power supply voltage with an accuracy of 2 decimal digits.

6. Summary of Technical Data

6.1 General Technical Data

Temperature range	0...50°C ambient temperature
Humidity	90% non-condensing
	via CompactPCI Bus: nominal voltage: 3.3 V (5 V tolerant) current consumption: maximum at 3.3 V: 25 mA maximum at 5 V: 125 mA
Connectors	<p>USB1 - external USB 2.0 interface (X800, USB-socket type A)</p> <p>USB2 - external USB 2.0 interface (X810, USB-socket type A)</p> <p>USB3 - external USB 2.0 interface (X900, USB-socket type A)</p> <p>USB4 - external USB 2.0 interface (X910, USB-socket type A)</p> <p>USB5 - external USB 2.0 interface (X1000, USB-socket type A)</p> <p>USB8 - internal USB 2.0 interface (X1010, 5-pin DUBOX connector, male, (fci connect 76382-305LF))</p> <p>CPCI - CompactPCI board connector (X100, 132-pin male connector)</p> <p>Only for test- and programming purposes: X601 - (6-pin SMD socket terminal strip)</p> <p>Only CPCI-USB-5-CF/SD (esd order number: I.2326.02): CompactFlash - CompactFlash card slot (X700) for CompactFlash type I cards SD - Secure Digital card slot (X710) for SD-memory cards</p>
Dimensions	100 mm x 160 mm
Weight	approx. 145 g

6.2 USB-Interface

Number	5x external USB, 1x internal USB
USB interface	USB 2.0, Hi-Speed, bit rate up to 480 Mbit/s
Host controller	NEC μ PD720101
Connector	<p>external USB (USB1-USB5): USB socket type A</p> <p>internal USB (USB8): 5-pin DUBOX connector, male (X1010), (fci connect 76382-305LF) Mates with Dubox CTW Housings and Contacts, Series 76347, 65239, 65240. see www.fciconnect.com for details</p>

6.3 CompactPCI Bus

Host bus	PCI-Bus according to PCI Local Bus Specification 2.2
PCI-data/address bus	32 Bit, 33 MHz
Controller	NEC μ PD720101
Board dimension	according to CompactPCI-Specification, Rev. 2.2
Connector	
Connector coding	Universal-Board, not keyed (3.3 V or 5 V signalling voltage)

6.4 CompactFlash Interface

Configuration	- CompactFlash card slot according to CompactFlash™ Specification, 'True-IDE' mode - suitable for type I cards
Power supply voltage	$V_{CF} = 3,3 \text{ V} \pm 5 \%$
Fixing	2 holes, 3.2 mm each for optional fixing of the CompactFlash card
Controller	USB 2.0 Flash Media card controller

6.5 Secure Digital Interface

Configuration	- SD memory card slot compatible to SD Memory Card Specifications Version 1.1 - suitable for Secure Digital (SD) cards
Power supply voltage	$V_{CC} = 5 \text{ V} \pm 5 \%$
Fixing	2 holes, 3.2 mm each for optional fixing of the SD card
Controller	USB 2.0 Flash Media card controller

6.6 System Health Controller

Type	Atmel AVR® 8-bit microcontroller
Functionality	- controls LEDs - measures current values of the local 3.3 V- and 5 V-power supply voltage - monitoring the status of the USB interfaces - sequentially powering up the USB ports

6.7 Software Support

The CPCI-USB-5 runs with the standard USB-serial system drivers of common operating systems.

6.8 Order Information

Type	Description	Order No.
CPCI- USB-5	CPCI USB 2.0 interface with 5x USB 2.0 via front panel, 1x USB 2.0 via on-board connector	I.2326.01
CPCI-USB-5-CF/SD	CPCI USB 2.0 interface with 5x USB 2.0 via front panel, 1x USB 2.0 via on-board connector, 1x CompactFlash card interface * 1x SD card interface *	I.2326.02
Accessories:		
CPCI-USB-5-MD	Hardware manual in German	I.2326.20
CPCI-USB-5-ME	Hardware manual in English	I.2326.20

* Pluggable storage media are not included in the scope of delivery.

Table 1: Order information

7. Connector Assignment

7.1 External USB (USB 1 - USB 5)

Device connector: USB connector type A

Pin Position:

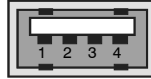

Pin Assignment:

Pin	Signal
1	V_{BUS}
2	D-
3	D+
4	GND

Signal Description:

V_{BUS} ... +5 V power supply voltage
D+, D-... USB signal lines Data+, Data-
GND... Reference potential

7.2 Internal USB

Device connector: 5-pin DUBOX connector, male (fci connect 76382-305LF)
Line connector: Dubox CTW Housings and Contacts, Series 76347, 65239, 65240,
see www.fciconnect.com for details

Pin Position:

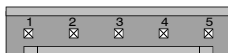

Pin Assignment:

Pin	Signal
1	V _{BUS}
2	D+
3	D-
4	GND
5	Shield (shielding)

Signal Description:

V_{BUS}... +5 V power supply voltage
D+, D-... USB signal lines Data+, Data-
GND... Reference potential