



CAN-USB/2

USB 2.0-CAN-Interface



Hardware Installation and technical Data

to Product C.2066.xx



NOTE

The information in this document has been carefully checked and is believed to be entirely reliable. **esd** makes no warranty of any kind with regard to the material in this document, and assumes no responsibility for any errors that may appear in this document. **esd** reserves the right to make changes without notice to this, or any of its products, to improve reliability, performance or design.

esd assumes no responsibility for the use of any circuitry other than circuitry which is part of a product of **esd gmbh**.

esd does not convey to the purchaser of the product described herein any license under the patent rights of **esd gmbh** nor the rights of others.

esd electronic system design gmbh
Vahrenwalder Str. 207
30165 Hannover
Germany

Phone: +49-511-372 98-0
Fax: +49-511-372 98-68
E-mail: info@esd-electronics.com
Internet: www.esd-electronics.com

USA / Canada:
esd electronics Inc.
525 Bernardston Road
Suite 1
Greenfield, MA 01301
USA

Phone: +1-800-732-8006
Fax: +1-800-732-8093
E-mail: us-sales@esd-electronics.com
Internet: www.esd-electronics.us

Document file:	I:\texte\Doku\MANUALS\CAN\USB-2\Englisch\USB-2_01.en9
Date of print:	22.06.2006

PCB version:	CAN-USB/2 Rev. 1.2
---------------------	--------------------

Changes in chapters

The changes in the document listed below affect changes in the hardware as well as changes in the description of facts only.

Chapter	Changes versus previous version
-	First issue

Technical details are subject to change without further notice.

This page is intentionally left blank.

Content

1. Overview	3
1.1 Module Description	3
1.2 Case View with LED and Connector Description	4
1.3 LED-Displays	5
2. Hardware Installation	6
3. Summary of technical Data	7
3.1 General technical Data	7
3.2 USB-Interface and Microcontroller	7
3.3 CAN Interface	8
3.4 Software Support	8
3.5 Order Information	9
4. Connector Assignment	10
4.1 CAN Interface at DSUB9 Connector	10
4.2 USB-Socket	11
5. Correctly Wiring Electrically Isolated CAN Networks	12
6. CAN-Bus Troubleshooting Guide	16
6.1 Termination	16
6.2 CAN_H/CAN_L Voltage	17
6.3 Ground	17
6.4 CAN Transceiver Resistance Test	18

This page is intentionally left blank.



1. Overview

1.1 Module Description

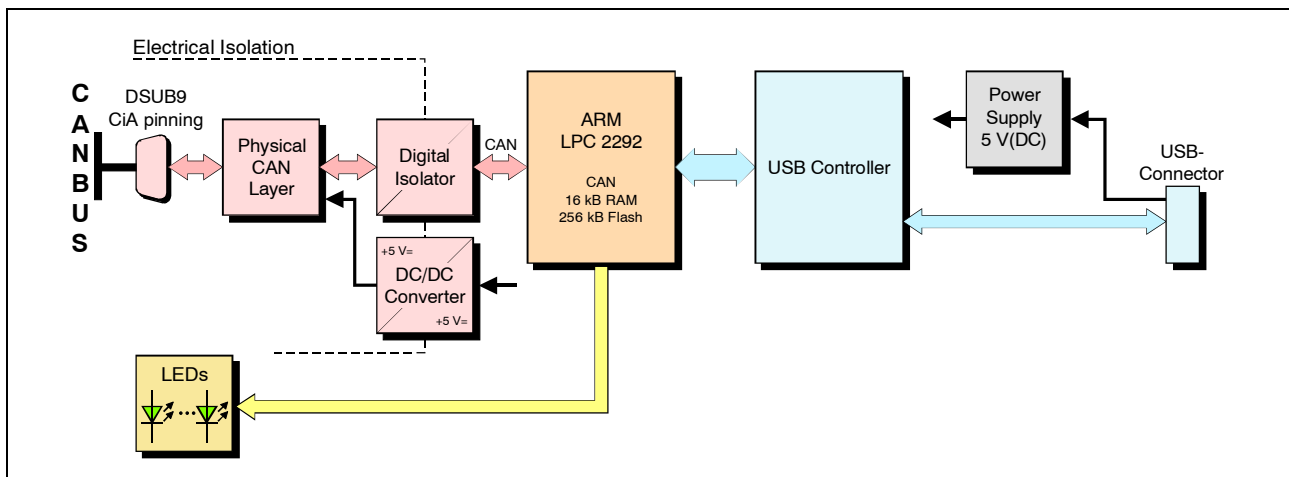

Figure 1.1: Block-circuit diagram of CAN-USB/2 module

The CAN-USB/2 module is an intelligent CAN interface with an ARM LPC2292 micro controller for local CAN data management. The module supports the USB 2.0 Hi-Speed interface with data transfer rates of 480 Mbit/s.

The ISO 11898-compliant CAN interface allows a maximum data transfer rate of 1 Mbit/s. Like many other features of CAN interfaces, the bit rate can be set by means of software. CAN interface and other voltage potentials are electrically isolated by means of a digital isolator and DC/DC converters.

The supply voltage is fed via the USB bus.

The module is equipped with four green LEDs in the front panel which indicate the current module status.



1.2 Case View with LED and Connector Description

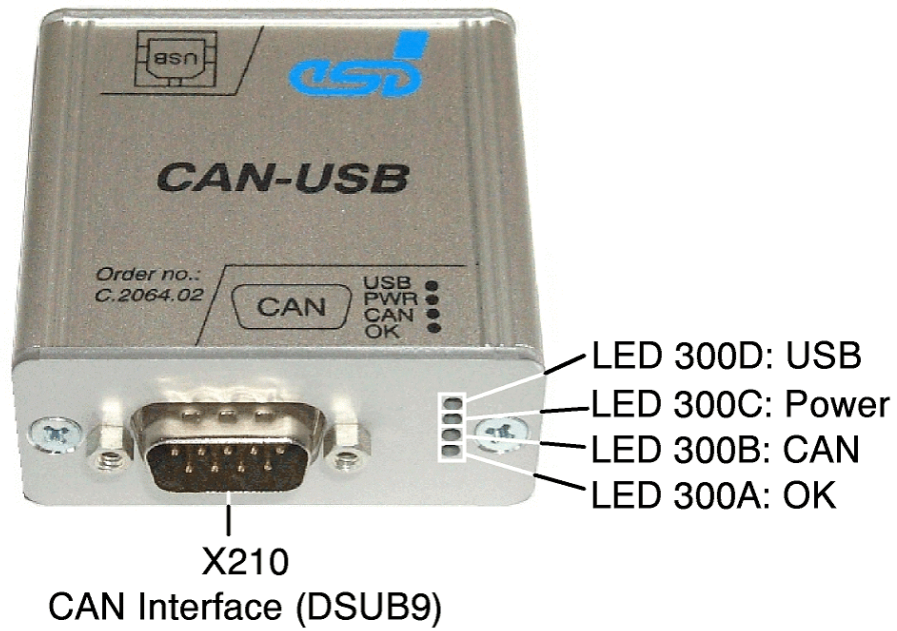

Figure 1.2.1: CAN Interface and LEDs



Figure 1.2.2: USB Interface



1.3 LED-Displays

LED	NAME	Status	Description
LED300D	USB	on	USB module is enumerated (a node-ID is assigned to the USB module)
		short-time switch off	the module receives data from USB bus or sends data on USB bus
LED300C	Power	on	module is in operation, the 5 V power supply is applied to the module
LED300B	CAN	flashes	data is received or send on the CAN bus
LED300A	OK	on	CAN interface is initialized, bit rates are set
		off	CAN Error occurred

Table 1.3: Description of LED display

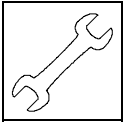

2. Hardware Installation

Installation procedure:

1. Switch off the PC and all connected peripheral devices (monitor, printer, etc.). Additionally, switch off all other CAN devices to whose network the CAN module is to be connected in this procedure.
2. Connect the CAN-USB/2-module with the USB bus of the PC.
3. Connect the CAN bus to the 9-pin male DSUB connector.
Please remember that the CAN bus has to be terminated at both ends. **esd** offers T-connectors and terminators. Additionally, the CAN-GND-signal has to be grounded at *exactly one* point in the CAN network. Therefore the CAN termination connectors have got a grounding contact. A CAN device whose CAN interface is not electrically isolated corresponds to the grounding of the CAN-GND.
4. Connect your PC to mains again.
5. Switch on the PC, the peripheral devices and the other CAN bus devices.
6. End of hardware installation.

Note: The software installation is described in the manual 'CAN-API, Installation Guide'.

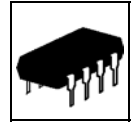

3. Summary of technical Data

3.1 General technical Data

Temperature range	0...50°C ambient temperature
Humidity	90 %, non-condensing
Power supply	via USB 2.0 bus, nominal voltage: 5 V current consumption: max. 250 mA *
Connectors	X210 (DSUB9/male) - CAN bus X300 (USB socket, series B) - USB bus X200 (intern) - Service interface
Case dimensions	55 mm x 55 mm x 25 mm
IP-rating	IP 40
Weight	70 g

Table 3.1: General Data of CAN-USB/2-Module

*** Note:** Please note that the current consumption of the module of 250 mA has to be supplied (high powered bus-powered device).
The maximum current consumption of 250 mA has to be guaranteed also if a hub is used. Therefore it is highly recommended to use a self-powered hub.

3.2 USB-Interface and Microcontroller

USB controller	PLX NET2272
USB-interface	USB 2.0, bitrate up to 480 Mbit/s
Microcontroller	ARM LPC 2292
Memory	3 k x 16 bit SRAM, 64 k x 16 bit flash EPROM

Table 3.2: USB interface and microcontroller

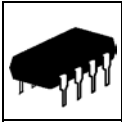

3.3 CAN Interface

Number of CAN interfaces	1x CAN
CAN controller	LPC2292
CAN protocol	Basic-CAN 2.0A/B
Physical Layer	according to ISO 11898, transmission rate programmable from 10 Kbit/s to 1 Mbit/s
Bus termination	has to be set externally
Electrical isolation of CAN-interfaces from other units	via digital isolators and DC/DC converters

Table 3.3: Data of CAN interface

3.4 Software Support

For CAN-USB/2 drivers for Windows and Linux are available.

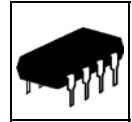

3.5 Order Information

Type	Features	Order No.
CAN-USB/2	1 x CAN 2.0A/B, ISO 11898, USB 2.0	C.2066.02
CAN-DRV-LCD	Object-Licence for Windows and Linux	C.1101.02
CAN-USB/2-Co	CANopen master/slave object licence	C.2066.12
CAN-USB/2-ME	User manual in English. 1*)	C.2066.21
CAN-API-ME	CAN-API manual in English to C.1101.02 1*)	C.2001.21
CAN-USB/2-ENG	Engineering manual in English 2*) Content: Circuit diagrams, PCB top overlay drawing, data sheets of significant components	C.2066.25

1*) If ordered together with the module, the manual is included in the shipment.

2*) This manual is liable for costs, please contact our support.

Table 3.5: Order information

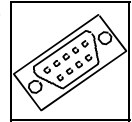

4. Connector Assignment

4.1 CAN Interface at DSUB9 Connector

The connector is a 9-pin male DSUB connector.

Pin Position:

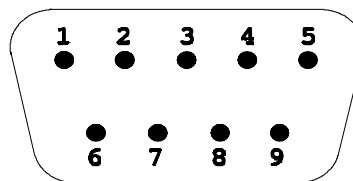

Pin Assignment:

Signal	Pin		Signal
(CAN_GND)	6	1	reserved
CAN_H		2	CAN_L
reserved	7	3	CAN_GND
reserved		4	reserved
reserved	8	5	Shield
reserved		9	

9-pin DSUB connector

Signal description:

CAN_L, CAN_H...	CAN signal lines
CAN_GND ...	reference potential of local CAN physical layer
(CAN_GND) ...	optional reference potential of local CAN physical layer
Shield...	Shielding (connected with case of 9-pin DSUB connector)
reserved ...	reserved for future applications

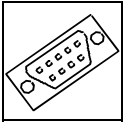

Connector assignment

4.2 USB-Socket

Attention: The module may only be operated at USB nets with USB interface version numbers ≥ 1.1 -interface!
However, note that using versions earlier than 2.0 reduces the data transfer rate.

Pin position:

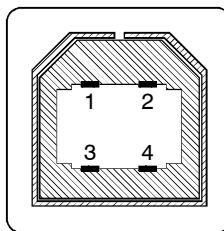

Pin Assignment:

Pin	Signal
1	V_{BUS}
2	D-
3	D+
4	GND
Shell	Shield

USB socket (series B)

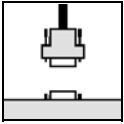

Wiring

5. Correctly Wiring Electrically Isolated CAN Networks

Generally all instructions applying for wiring regarding an electromagnetic compatible installation, wiring, cross sections of wires, material to be used, minimum distances, lightning protection, etc. have to be followed.

The following **general rules** for the CAN wiring must be followed:

1.	A CAN net must not branch (exception: short dead-end feeders) and has to be terminated by the wave impedance of the wire (generally $120\ \Omega \pm 10\%$) at both ends (between the signals CAN_L and CAN_H and not at GND)!
2.	A CAN data wire requires two twisted wires and a wire to conduct the reference potential (CAN_GND)! For this the shield of the wire should be used!
3.	The reference potential CAN_GND has to be connected to the earth potential (PE) at one point. Exactly one connection to earth has to be established!
4.	The bit rate has to be adapted to the wire length.
5.	Dead-end feeders have to kept as short as possible ($l < 0.3\ \text{m}$)!
6.	When using double shielded wires the external shield has to be connected to the earth potential (PE) at one point. There must be not more than one connection to earth.
7.	A suitable type of wire (wave impedance ca. $120\ \Omega \pm 10\%$) has to be used and the voltage loss in the wire has to be considered!
8.	CAN wires should not be laid directly next to disturbing sources. If this cannot be avoided, double shielded wires are preferable.

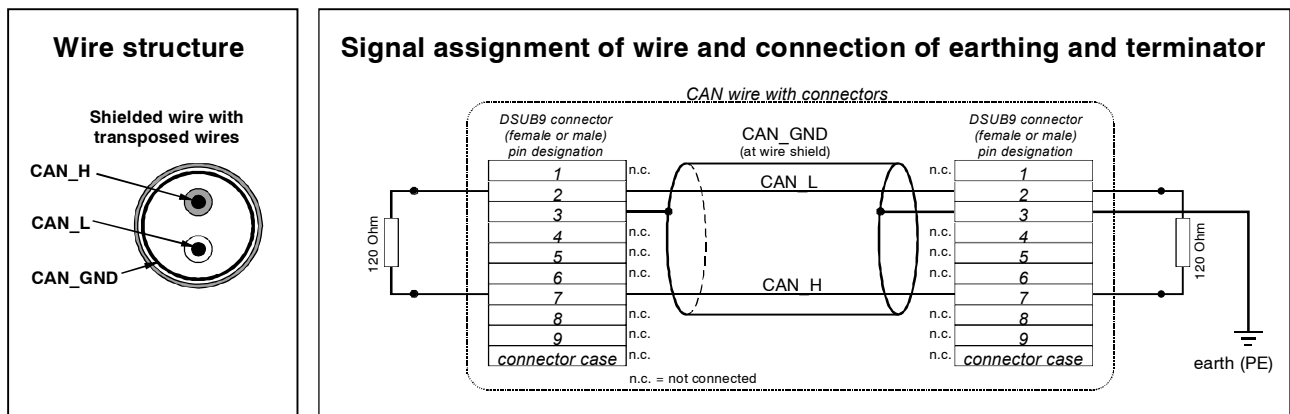
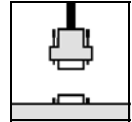

Figure: Structure and connection of wire



Cabling

- for devices which have only one CAN connector per net use T-connector and dead-end feeder (shorter than 0.3 m) (available as accessory)

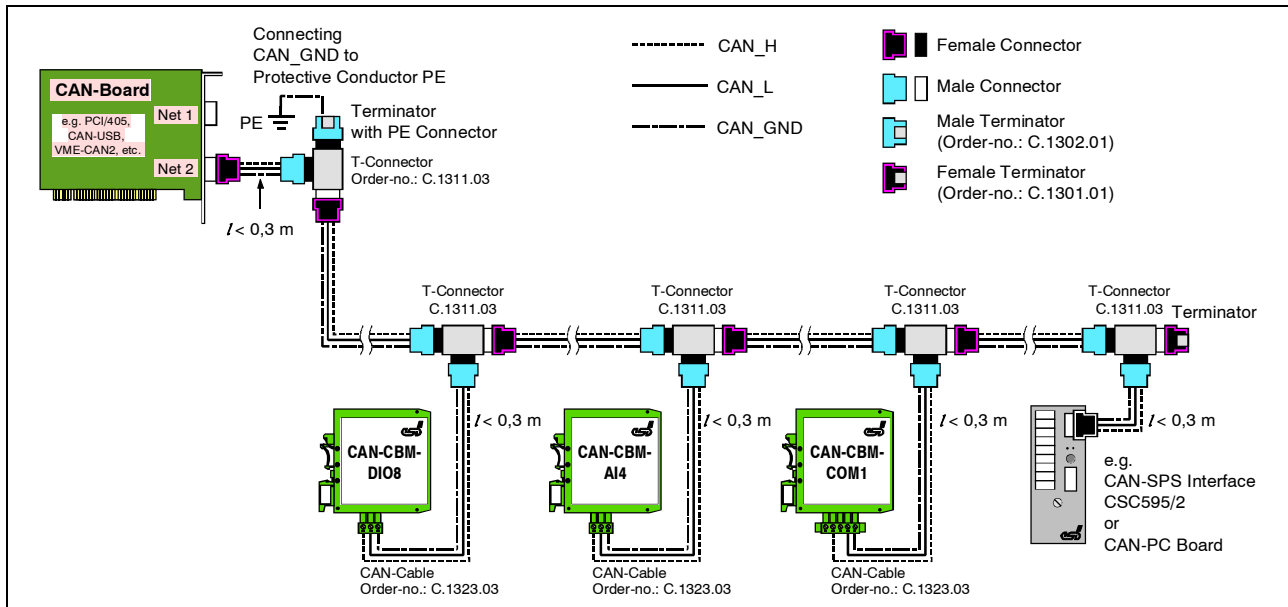

Figure: Example for correct wiring (when using single shielded wires)

Terminal Resistance

- use **external** terminator, because this can later be found again more easily!
- 9-pin DSUB-terminator with male and female contacts and earth terminal are available as accessories

Earthing

- CAN_GND has to be conducted in the CAN wire, because the individual esd modules are electrically isolated from each other!
- CAN_GND has to be connected to the earth potential (PE) at **exactly one** point in the net!
- each CAN user without electrically isolated interface works as an earthing, therefore: do not connect more than one user without potential separation!
- Earthing CAN e.g. be made at a connector

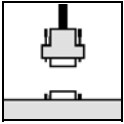

Wiring

Wire Length

- Optical couplers are delaying the CAN signals. By using fast optical couplers and testing each board at 1 Mbit/s, however, esd CAN guarantee a reachable length of 37 m at 1 Mbit/s for most esd CAN modules within a closed net without impedance disturbances like e.g. longer dead-end feeders. (Exception: CAN-CBM-DIO8, -AI4 and AO4 (these modules work only up to 10 m with 1 Mbit/s))

Bit rate [Kbit/s]	Typical values of reachable wire length with esd interface l_{\max} [m]	CiA recommendations (07/95) for reachable wire lengths l_{\min} [m]
1000	37	25
800	59	50
666.6	80	-
500	130	100
333.3	180	-
250	270	250
166	420	-
125	570	500
100	710	650
66.6	1000	-
50	1400	1000
33.3	2000	-
20	3600	2500
12.5	5400	-
10	7300	5000

Table: Reachable wire lengths depending on the bit rate when using esd-CAN interfaces

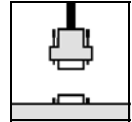

Examples for CAN Wires

Manufacturer	Type of wire
U.I. LAPP GmbH Schulze-Delitzsch-Straße 25 70565 Stuttgart Germany www.lappkabel.de	e.g. UNITRONIC ®-BUS CAN UL/CSA (UL/CSA approved) UNITRONIC ®-BUS-FD P CAN UL/CSA (UL/CSA approved)
ConCab GmbH Äußerer Eichwald 74535 Mainhardt Germany www.concab.de	e.g. BUS-PVC-C (1 x 2 x 0.22 mm ²) Order No.: 93 022 016 (UL appr.) BUS-Schleppflex-PUR-C (1 x 2 x 0.25 mm ²) Order No.: 94 025 016 (UL appr.)
SAB Bröckskes GmbH&Co. KG Grefrather Straße 204-212b 41749 Viersen Germany www.sab-brockskes.de	e.g. SABIX® CB 620 (1 x 2 x 0.25 mm ²) Order No.: 56202251 CB 627 (1 x 2 x 0.25 mm ²) Order No.: 06272251 (UL appr.)

Note: Completely configured CAN wires can be ordered from **esd**.

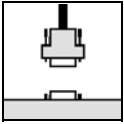

6. CAN-Bus Troubleshooting Guide

The CAN-Bus Troubleshooting Guide is a guide to find and eliminate the most frequent hardware-error causes in the wiring of CAN-networks.

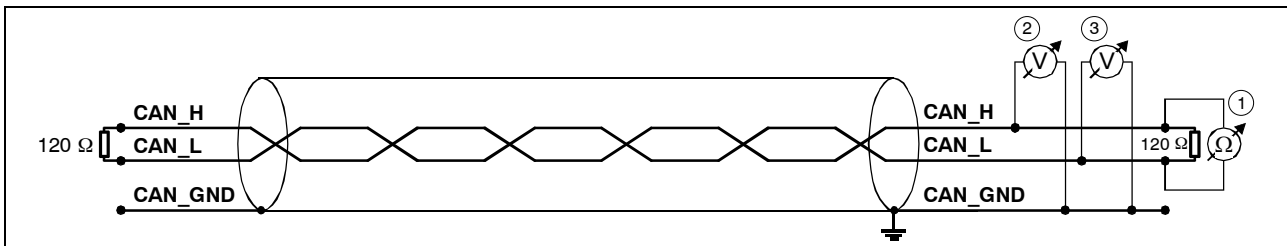

Figure: Simplified diagram of a CAN network

6.1 Termination

The termination is used to match impedance of a node to the impedance of the transmission line being used. When impedance is mismatched, the transmitted signal is not completely absorbed by the load and a portion is reflected back into the transmission line. If the source, transmission line and load impedance are equal these reflections are eliminated. This test measures the series resistance of the CAN data pair conductors and the attached terminating resistors.

To test it, please

1. Turn off all power supplies of the attached CAN nodes.
2. Measure the DC resistance between CAN_H and CAN_L at the middle and ends of the network (1) (see figure above).

The measured value should be between 50 and 70 Ω. The measured value should be nearly the same at each point of the network.

If the value is below 50 Ω, please make sure that:

- there is no short circuit between CAN_H and CAN_L wiring
- there are not more than two terminating resistors
- the nodes do not have faulty transceivers.

If the value is higher than 70 Ω, please make sure that:

- there are no open circuits in CAN_H or CAN_L wiring
- your bus system has two terminating resistors (one at each end) and that they are 120 Ω each.

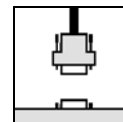

6.2 CAN_H/CAN_L Voltage

Each node contains a CAN transceiver that outputs differential signals. When the network communication is idle the CAN_H and CAN_L voltages are approximately 2.5 volts. Faulty transceivers can cause the idle voltages to vary and disrupt network communication.

To test for faulty transceivers, please

1. Turn on all supplies.
2. Stop all network communication.
3. Measure the DC voltage between CAN_H and GND **2** (see figure above).
4. Measure the DC voltage between CAN_L and GND **3** (see figure above).

Normally the voltage should be between 2.0 V and 4.0 V.

If it is lower than 2.0 V or higher than 4.0 V, it is possible that one or more nodes have faulty transceivers. For a voltage lower than 2.0 V please check CAN_H and CAN_L conductors for continuity. For a voltage higher than 4.0 V, please check for excessive voltage.

To find the node with a faulty transceiver please test the CAN transceiver resistance (see next page).

6.3 Ground

The shield of the CAN network has to be grounded at only one location. This test will indicate if the shielding is grounded in several places.

To test it, please

1. Disconnect the shield wire from the ground.
2. Measure the DC resistance between Shield and ground.
3. Connect Shield wire to ground.

The resistance should be higher than 1 M Ω . If it is lower, please search for additional grounding of the shield wires.

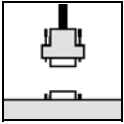

6.4 CAN Transceiver Resistance Test

CAN transceivers have one circuit that controls CAN_H and another circuit that controls CAN_L. Experience has shown that electrical damage to one or both of the circuits may increase the leakage current in these circuits.

To measure the current leakage through the CAN circuits, please use an resistance measuring device and:

1. Disconnect the node from the network. Leave the node unpowered (4) (see figure below).
2. Measure the DC resistance between CAN_H and CAN_GND (5) (see figure below).
3. Measure the DC resistance between CAN_L and CAN_GND (6) (see figure below).

Normally the resistance should be between 1 M Ω and 4 M Ω or higher. If it is lower than this range, the CAN transceiver is probably faulty.

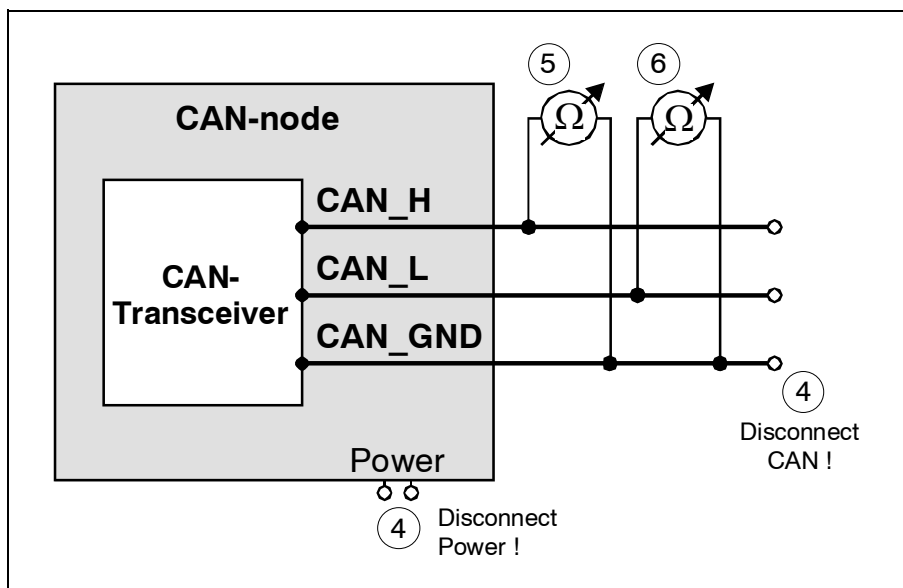

Figure: Simplified diagram of a CAN node

EG-KONFORMITÄTSERKLÄRUNG DECLARATION OF CONFORMITY



Adresse
Address

esd electronic system design gmbh
Vahrenwalder Str. 207
30165 Hannover
Germany

esd erklärt, daß das Produkt
esd declares, that the product

CAN-USB/2

Typ, Modell, Artikel-Nr.
Type, Model, Article No.

C.2066.xx

die Anforderungen der Normen
fullfills the requirements of the standards

EN 61000-6-3 (11/2005)
EN 61000-6-2 (03/2006)

gemäß folgendem Prüfbericht erfüllt.
according to test certificate.

H-K00-0272-06

Das Produkt entspricht damit den EG-Richtlinien
Therefore the product corresponds to the EU-Directives

89/336/EWG geändert durch
(changed by) 91/263/EWG,
92/31/EWG and 93/68/EWG

Diese Erklärung gilt für alle Exemplare, die das CE-Zeichen tragen und verliert ihre Gültigkeit,
wenn Veränderungen am Produkt vorgenommen werden.

This declaration is valid for all units with the CE label on it and it lose its validity if a modification is done on the product.

Name / *Name*
Funktion / *Title*
Datum / *Date*

Dr. Ing. Werner Schulze
Geschäftsführer / *Managing Director*
Hannover, den 26.04.2006

Rechtsgültige Unterschrift / *authorized Signature*